

HAMMOND EXCHANGE

5830-5988 Roswell Rd NE, Sandy Springs, GA 30328

Jamestown

HAMMOND EXCHANGE

SUITE 5942 - 2,007 SF

RETAIL SPACE AVAILABLE

- Retail space
- Neighboring MyEyeDr. and Head2Toe Spa
- Dedicated on-site parking field
- Availability: Immediate

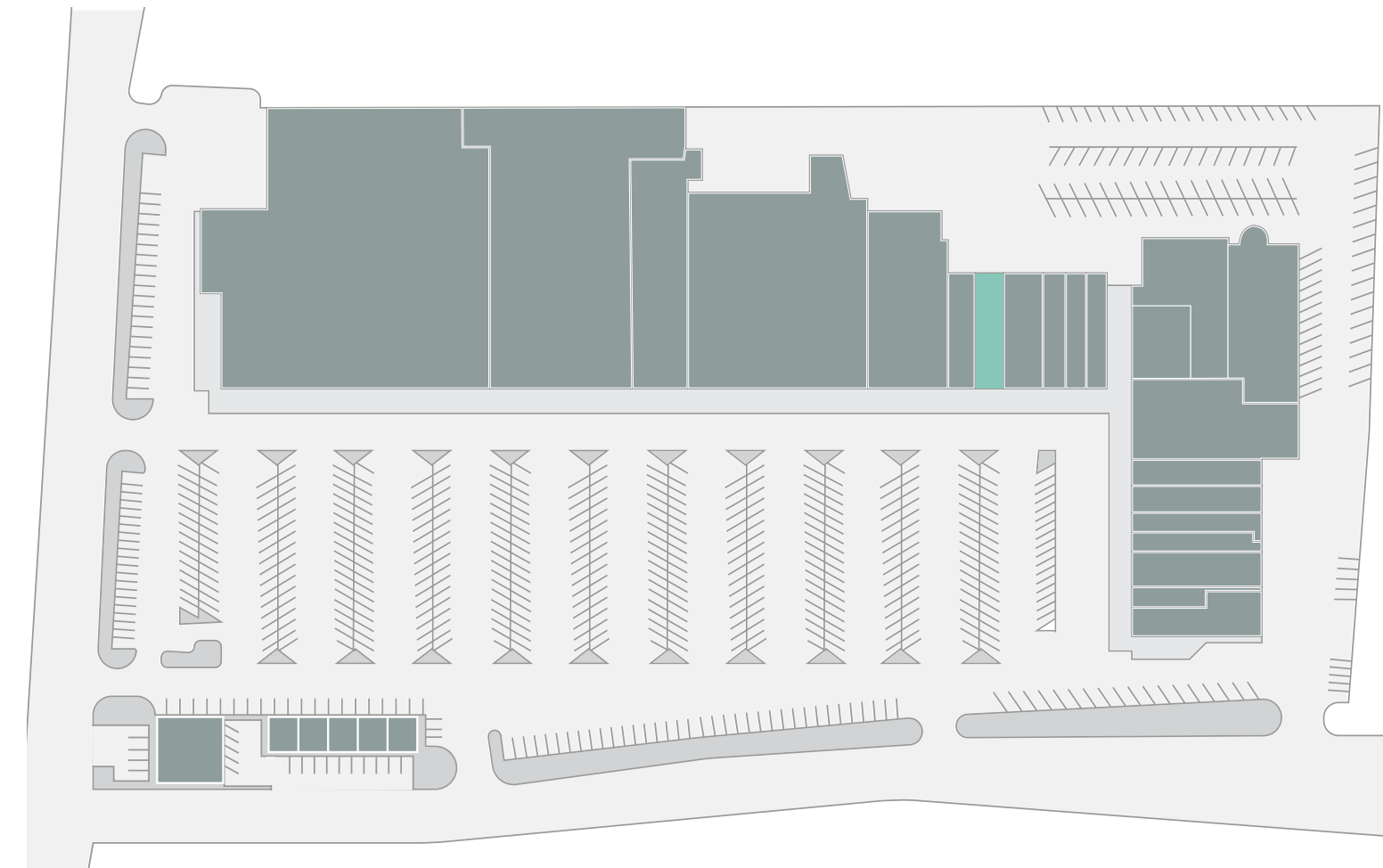

VIRTUAL TOUR

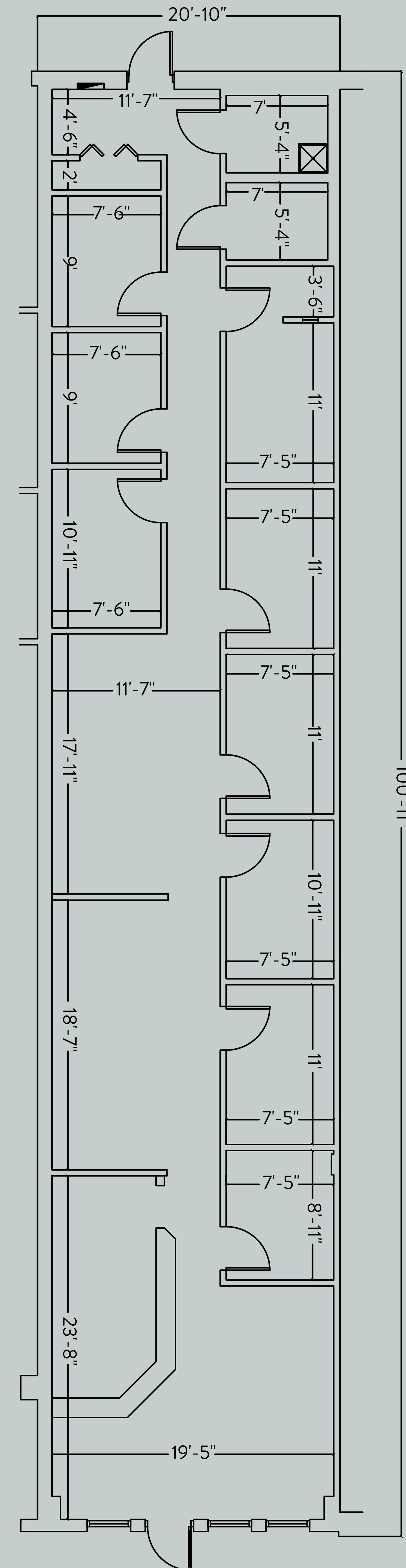

HAMMOND EXCHANGE

5830-5988 Roswell Rd NE, Sandy Springs, GA 30328



For leasing information, please contact:

JOHN ORTNER | 850.543.3924

JOHN.ORTNER@JAMESTOWNLP.COM